

This article was downloaded by:

On: 25 January 2011

Access details: *Access Details: Free Access*

Publisher *Taylor & Francis*

Informa Ltd Registered in England and Wales Registered Number: 1072954 Registered office: Mortimer House, 37-41 Mortimer Street, London W1T 3JH, UK



Liquid Crystals

Publication details, including instructions for authors and subscription information:

<http://www.informaworld.com/smpp/title~content=t713926090>

Structure and energy of the wall separating two states in surface-stabilized smectic C chevron cells

N. Vaupotic; M. Copic

Online publication date: 06 August 2010

To cite this Article Vaupotic, N. and Copic, M.(1999) 'Structure and energy of the wall separating two states in surface-stabilized smectic C chevron cells', *Liquid Crystals*, 26: 10, 1429 – 1435

To link to this Article: DOI: 10.1080/026782999203751

URL: <http://dx.doi.org/10.1080/026782999203751>

PLEASE SCROLL DOWN FOR ARTICLE

Full terms and conditions of use: <http://www.informaworld.com/terms-and-conditions-of-access.pdf>

This article may be used for research, teaching and private study purposes. Any substantial or systematic reproduction, re-distribution, re-selling, loan or sub-licensing, systematic supply or distribution in any form to anyone is expressly forbidden.

The publisher does not give any warranty express or implied or make any representation that the contents will be complete or accurate or up to date. The accuracy of any instructions, formulae and drug doses should be independently verified with primary sources. The publisher shall not be liable for any loss, actions, claims, proceedings, demand or costs or damages whatsoever or howsoever caused arising directly or indirectly in connection with or arising out of the use of this material.

Structure and energy of the wall separating two states in surface-stabilized smectic C chevron cells

N. VAUPOTIČ*†‡ and M. ČOPIČ‡§

†Department of Physics, Faculty of Education, University of Maribor,
Koroška 160, SI-2000 Maribor, Slovenia

‡Department of Physics, Faculty of Mathematics and Physics,
University of Ljubljana, Jadranska 19, SI-1000 Ljubljana, Slovenia

§Institute Jožef Stefan, Jamova 39, SI-1000 Ljubljana, Slovenia

(Received 8 January 1999; accepted 30 March 1999)

We use a Landau–de Gennes model to study the structure of the wall formed between two oppositely switched areas (pixels) in surface stabilized smectic C cells with uniform chevron direction. We find the width of the wall and calculate the energy associated with its formation. This approach also allows us to determine the effect of the temperature on the pixel wall properties. We predict analytically and calculate numerically that both the wall energy and the wall width obey a power law dependence on temperature with the exponents $3/2$ and $-1/2$, respectively.

1. Introduction

The chevron structure of the smectic layer is a rule in most surface-stabilized cells filled with either achiral or ferroelectric smectic C liquid crystals [1, 2]. In such cells the chevron structure is formed because of the mismatch between the natural layer thickness of the SmC phase (d_c) and the periodicity determined by the surface (d_0), figure 1(a). The chevron structure is thus a result of the competition between the sample history (the former structure is usually the smectic A and in this phase the smectic layer position is frozen-in at the surface) and the thermodynamics of the smectic C phase which requires a different periodicity. The energetically most favourable way to fulfil both requirements is to form a chevron structure.

Surface-stabilized ferroelectric liquid crystal cells are known to exhibit at least two stable director states, between which the cell can be switched by an external electric field, figure 1(b, c) [3]. Because of its possible applications the structure has attracted much attention from both experimentalists and theoreticians. Recently we have proposed the Landau–de Gennes model [4, 5] as a compact and simple model to study all the essential characteristics of the chevron structure. The director and layer structure was studied as a function of the relevant characteristic lengths entering the model, the surface anchoring conditions and temperature.

*Author for correspondence; e-mail: natasa.vaupotic@uni-mb.si

The usual experimental case is that the layer tilt angle (δ) is smaller than the molecular cone angle (ϑ). This leads to director bistability at the surface [6–10] which consequently leads to chevron bistability. In [4] we have also shown that $\delta < \vartheta$ is not a necessary condition for chevron bistability. Due to competition between the surface and bulk forces the nematic director does not remain in the plane of the smectic layer normal (the chevron structure is not planar) at the chevron tip and so there exist two stable director structures even when $\delta = \vartheta$ and the orientational anchoring at the surface is monostable.

An important reason for modelling surface-stabilized smectic C cells is to describe the switching dynamics between the stable director structures by an external electric field. In this paper we consider switching in cells with a uniform chevron direction everywhere in the cell. The work presented can be regarded as a basis for future work on the dynamics of switching and the nucleation of switching in surface-stabilized cells with uniform chevron direction.

In the present paper we study the properties of the wall separating two possible states of the director at the chevron interface that are N smectic layers apart. As in our previous papers, we assume that $\delta = \vartheta$ so that there is no surface bistability. In ferroelectric smectic C cells such opposite states can be established, for example, by an external electric field. In the modelling of two pixels with different director orientation, and the wall between

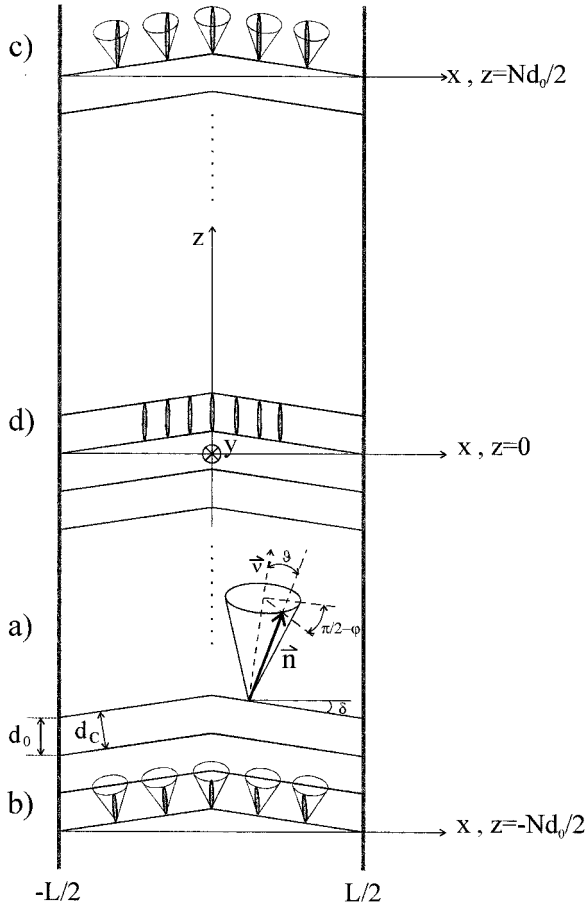

Figure 1. The chevron structure. (a) The structure is described by the molecular cone angle ϑ , the layer tilt angle δ and the director position on the cone φ . v is the smectic layer normal, L is the cell thickness, d_0 is the periodicity required by the surface and d_c is the periodicity required by the smectic C structure. (b) One stable director state with $\varphi=0$ at the chevron tip. (c) Another stable state with $\varphi=\pi$ at the chevron tip. (d) The structure at the centre of the wall is a planar chevron structure.

them, we use the geometry shown in figure 1. If the z -axis is chosen to point along the surfaces and along the chevron direction then at $z \leq -Nd_0/2$ the director is switched in one stable state, figure 1(b). At $z \geq Nd_0/2$ the director is switched to the other stable state, figure 1(c). We find the width of the area (wall) over which the director rotates from one stable state to the other and calculate the energy associated with the wall as a function of the number of smectic layers between the switched layers and can then make estimates of the size of the pixel required for switching to occur. Our approach, i.e. the use of the Landau type model, also allows us to determine the effect of temperature on the pixel wall properties. We show that both the wall energy and the wall width obey a power law dependence on temperature.

The plan of this paper is as follows. In §2 the geometry and the theoretical model are introduced. In §3 we discuss the numerical results, and summarize our conclusions in §4.

2. The model

We use the Landau–de Gennes model, based on the analogy between superconductors and smectics [11–13]. In the context of this model the smectic C structure is described by the nematic director \mathbf{n} and the complex smectic order parameter ψ :

$$\psi(\mathbf{r}) = \eta(\mathbf{r}) \exp[i\phi(\mathbf{r})]$$

where $\eta(\mathbf{r}) = |\psi(\mathbf{r})|$ is the magnitude of the smectic order parameter and $\phi(\mathbf{r})$ is the phase factor that determines the position of the smectic layers. The free energy density consists of nematic and smectic contribution [4, 5, 13]:

$$f = \frac{1}{2}K [(\nabla \cdot \mathbf{n})^2 + (\nabla \times \mathbf{n})^2] + c_{\parallel} |(\mathbf{n} \cdot \nabla - iq_0)\psi|^2 + c_{\perp} |\mathbf{n} \times \nabla \psi|^2 + D |(\mathbf{n} \times \nabla)^2 \psi|^2.$$

The parameter K is the nematic elastic constant. We use a one-constant approximation. The parameter c_{\parallel} is related to the de Gennes smectic compressibility constant [4]. The coefficient c_{\perp} is temperature dependent: $c_{\perp} = c_{\perp 0}(T/T_{AC} - 1)$, and determines the phase transition from the smectic A to the smectic C phase at the bulk phase transition temperature T_{AC} . The coefficient D is positive and the term associated with it has two functions. First, it stabilizes finite director tilt with respect to the smectic layer normal; second, it provides an energy cost to smectic layer curvature. The periodicity required by the surface is $q_0 = 2\pi/d_0$, where d_0 is the smectic layer thickness in the smectic A phase.

The bulk value of the molecular cone angle that follows from the model is

$$\tan \vartheta_B = [c_{\perp}/(2Dq_0^2)]^{1/2}. \quad (1)$$

2.1. Calculation details

The co-ordinate system used for calculations is shown in figure 1. We assume that the director and the smectic order parameter are functions of x and z only, and for numerical calculations we express the director by its components along the x -, y - and z -axes:

$$\mathbf{n}(x, z) = [k(x, z), l(x, z), m(x, z)],$$

where $m = (1 - k^2 - l^2)^{1/2}$, because $|\mathbf{n}(\mathbf{r})| = 1$. The smectic order parameter phase factor is:

$$\phi(x, z) = q_0 [z + u(x, z)].$$

We have introduced the layer displacement field $u(x, z)$ which describes the departure from the planar layer configuration. The variables used in the numerical calculations

are $k(x, z)$, $l(x, z)$ and $u(x, z)$. The results, however, are presented in terms of the molecular cone angle ϑ , the director position on the cone φ and the smectic layer tilt δ .

In the modelling of two pixels with different director orientation and the wall between them, we use the geometry shown in figure 1. At $z \leq -Nd_0/2$ the director is switched in one stable state with $\varphi = 0$ at the chevron tip. We shall refer to this state as a \bullet -state, because in figure 1(b) the director at the chevron tip points out of the paper in the $-y$ -direction. At $z \geq Nd_0/2$ the director is switched to the other stable state with $\varphi = \pi$ at the chevron tip (\times -state, since the director at the chevron tip points inside the paper, i.e. in the y -direction). These are assumed to be strong boundary conditions at $z = -Nd_0/2$ and $z = Nd_0/2$. The wall is centred around $z = 0$.

2.1.1. Assumptions

In calculating the structure and the energy of the wall several reasonable assumptions are employed:

- (1) We assume non-polar surface orientational anchoring and study only cells with symmetric chevron structure. In the symmetric chevron structure we expect a symmetric structure of the wall formed between two stable states. As a result the structure in the smectic layer that lies in the centre of the wall (at $z = 0$) has to be a planar chevron structure in which the director lies in the xz -plane everywhere in the layer, see figure 1(d).
- (2) We assume that the cell thickness is much larger than the width of the chevron tip. As a result the effect of the surface on the structure around the chevron tip is disregarded.
- (3) The results obtained from our previous work are used to simplify the model. The most important simplification follows from the result that the gradient terms in the director components that follow from the smectic term $D|(\mathbf{n} \times \nabla)^2 \psi|^2$ only slightly renormalize the nematic elastic constant K and as such they can be neglected. The only relevant gradient term in $D|(\mathbf{n} \times \nabla)^2 \psi|^2$ is the term including the second spatial derivative of the displacement u .
- (4) We assume that the displacement field $u(\mathbf{r})$ is a function of x only. This means that the smectic layer orientation along the z -axis does not change significantly, i.e. the director switches from one state to the other mostly by changing the angles ϑ and φ . This assumption was checked for validity.
- (5) We also assume that the magnitude of the smectic order parameter is constant and equal to its bulk value: $\eta(\mathbf{r}) = \eta_B$.

2.1.2. Dimensionless free energy density

For computational purposes it is useful to write the energy in dimensionless form. We scale the length in the x -direction with respect to the characteristic width of the chevron tip $\lambda_{ch} = (2D/|c_{\perp}|)^{1/2}$ [4, 5] and thus introduce the following dimensionless length:

$$\xi = x/\lambda_{ch}.$$

The co-ordinate z is scaled with respect to the layer thickness (d_0) required by the surface:

$$\zeta = z/d_0.$$

In addition we introduce the following dimensionless parameters and constants:

$$C_K = \frac{K}{2Dq_0^2\eta_B^2}, \quad C_R = \frac{c_{\parallel}}{|c_{\perp}|}, \quad R = \lambda_{ch}/d_0 = \frac{1}{2\pi \tan \vartheta_B}$$

and

$$w(\xi) = \frac{1}{\lambda_{ch}} \frac{\partial u(\xi)}{\partial \xi}.$$

The dimensionless free energy G is defined as

$$G = \frac{1}{2\pi|c_{\perp}|\eta_B^2 q_0 \lambda_{ch}} \iint f(x, z) dx dz = \iint [g_n(\xi, \zeta) + g_s(\xi, \zeta)] d\xi d\zeta$$

where (the subscripts ζ and ξ denote a partial derivative with respect to ζ and ξ , respectively)

$$g_n(\xi, \zeta) = \frac{1}{2} C_K \left[(R^2 \ell_{\zeta}^2 + \ell_{\xi}^2) \left(1 + \frac{\ell^2}{m^2} \right) + (R^2 k_{\zeta}^2 + k_{\xi}^2) \left(1 + \frac{k^2}{m^2} \right) + \frac{2kl}{m^2} (R^2 k_{\zeta} l_{\zeta} + k_{\xi} l_{\xi}) + \frac{2l}{m} R (k_{\zeta} l_{\xi} - l_{\zeta} k_{\xi}) \right] \quad (2)$$

is the dimensionless nematic free energy density; the dimensionless smectic free energy density is

$$g_s(\xi, \zeta) = C_R (wk + m - 1)^2 - B + \frac{1}{2 \tan^2 \vartheta_B} B^2 + \frac{1}{2} w_{\xi}^2 \quad (3)$$

where

$$B = \ell^2 + k^2 + w^2 (1 - k^2) - 2mkw.$$

The spatial dependences of $k(\xi, \zeta)$, $l(\xi, \zeta)$ and $u(\xi)$ are found in the following way. First we find the solution for one single layer [4]. In that case all the variables are functions of ξ only. We find spatial dependencies for $k(\xi)$, $l(\xi)$ and $u(\xi)$. When one solution is found we know

that $k(\xi)$, $-l(\xi)$ and $u(\xi)$ is also the structure with a minimum energy—that is the second bistable director structure. The first solution is then taken as a boundary condition in the smectic layer at $z = -Nd_0/2$ and the other as a boundary condition at $z = Nd_0/2$. Finally we study a two dimensional problem: we minimize the energy over $k(\xi, \zeta)$ and $l(\xi, \zeta)$ and employ a relaxation method to solve the coupled set of Euler–Lagrange equations obtained.

3. Numerical results

We first show results for the structure and energy of the wall formed between two switched regions at a constant temperature deep in the smectic C phase, i.e. far from the smectic C–smectic A or smectic C–nematic phase transition temperature. To present characteristic results we chose the following set of values [14, 15]:

$$\vartheta_B = 20^\circ, \quad d_0 = 3 \text{ nm}, \quad c_{\parallel}/|c_{\perp}| = 10, \quad K = 10^{-11} \text{ J m}^{-1}, \\ Dq_0^2 \eta_B^2 / K = 10^{-2}, \quad N = 120. \quad (4)$$

With these values the dimensionless parameters are: $C_K = 50$, $C_R = 10$ and $R = 0.45$. In the x -direction we extended the calculation to $x = \pm 30 \lambda_{ch}$. The typical width of the cell is $2 \mu\text{m}$, which is about $1500 \lambda_{ch}$ with the chosen set of parameters. Inside one layer significant variation of the variables $k(\xi, \zeta)$, $l(\xi, \zeta)$ and $u(\xi)$ occurs in a region of a width of a few typical chevron widths. Thus at $x = \pm 30 \lambda_{ch}$ we are already very far from the chevron tip and can take the following free boundary conditions at these values of x : $\partial l(\xi, \zeta) / \partial \xi = 0$, $\partial k(\xi, \zeta) / \partial \xi = 0$ and $\partial u(\xi) / \partial \xi = 0$.

In figures 2(a) and 2(b), respectively, we show the molecular cone angle variation along the ζ -axis at different values of ξ , and its variation along the ξ -axis at chosen values of ζ . We are considering only the symmetrical chevron structure where ϑ is a symmetric function along ξ around $\xi = 0$. Since the director at the chevron tip has to rotate from $\varphi = 0$ at $\zeta = -N/2$ to $\varphi = \pi$ at $\zeta = N/2$ the only director position at $\xi = 0$ and $\zeta = 0$ allowed by the symmetry is $\mathbf{n}(\xi = 0, \zeta = 0) = (0, 0, 1)$. This can also be seen from figure 2, where the molecular cone angle essentially reduces to 0 at $\zeta = 0$ and the chevron tip.

The crucial parameter which determines optical properties of the surface-stabilized smectic C liquid crystal cells is the director position on the cone. When such a cell is set between two properly aligned crossed polarizers one of the director states transmits light (bright state) and the other does not (dark state). In figures 3(a) and 3(b), respectively, we show the director rotation on the cone (φ) along the ζ -axis at different values of ξ , and its rotation along the ξ -axis at chosen

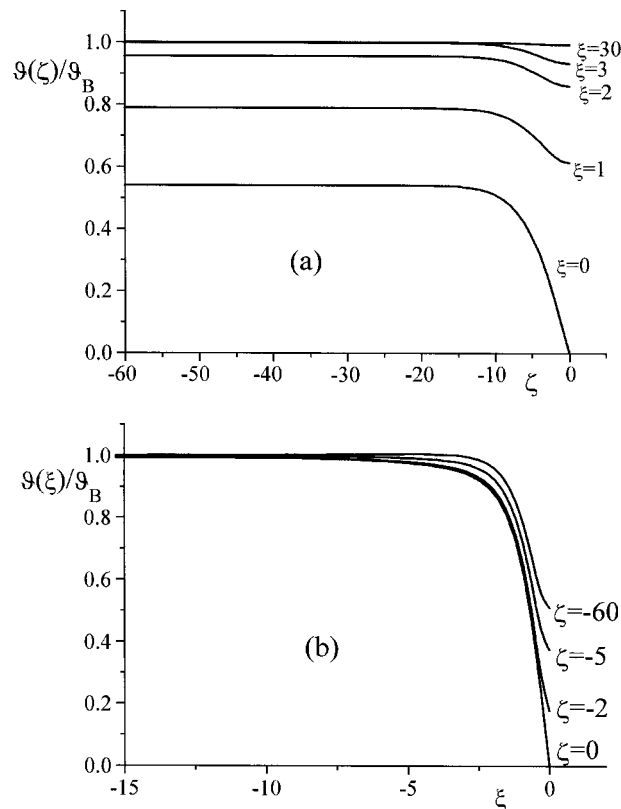

Figure 2. (a) The molecular cone angle variation along the ζ -axis at different values of ξ . (b) The molecular cone angle variation along the ξ -axis at chosen values of ζ . The number of smectic layers between the switched areas is $N = 120$.

values of ζ . It can be seen that the director rotation on the cone from one state to the other is localized around $\zeta = 0$. However [see figure 3(a)], the rotation on the cone along the ζ -axis (i.e. from one smectic layer to another) is significant at all values of ξ (while the molecular cone angle changes significantly along ζ only close to the chevron tip, i.e. at ξ close to 0). The main deformation in the smectic C structure is thus localized along the ζ -axis around $\xi = 0$ (the chevron tip) and along the ξ -axis around $\zeta = 0$ (the centre of the wall associated with the pixel switch).

We see that at $\zeta = 0$ the value of φ is $\varphi(\xi, \zeta = 0) = \pi/2$ for each ξ . The exception is the value of φ at $\xi = 0$, where $\vartheta = 0$ and φ is not defined. So in the smectic layer that lies between the two switched areas there is a planar chevron structure, where the director lies in the xz -plane everywhere in the layer.

In figure 4 we show the difference $\Delta g = g(\zeta) - g$ between the free energy density $g(\zeta)$ defined as

$$g(\zeta) = \int_{-L/(2\lambda_{ch})}^{L/(2\lambda_{ch})} [g_n(\xi, \zeta) + g_s(\xi, \zeta)] d\xi$$

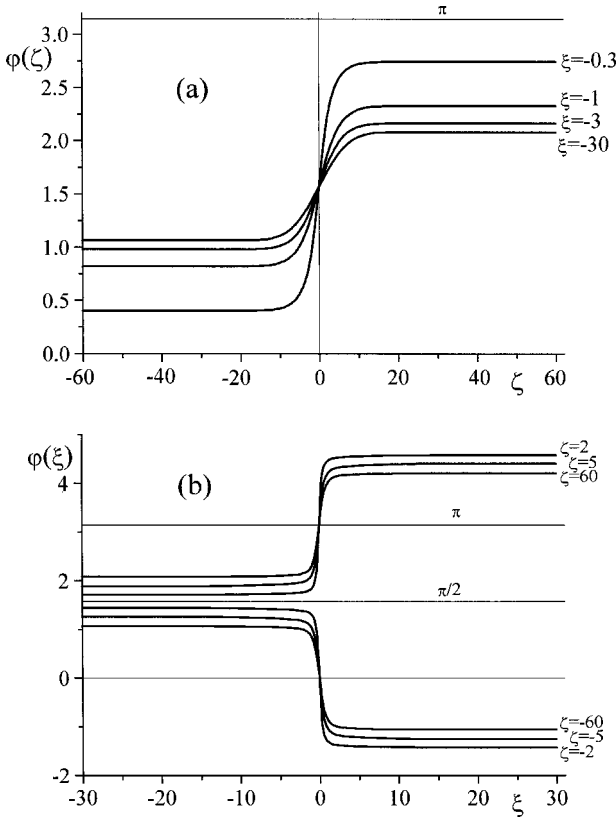

Figure 3. (a) The director rotation on the cone (φ) along the ζ -axis at different values of ξ . (b) The director rotation on the cone along the ξ -axis at chosen values of ζ . The structure is calculated for $-N/2 \leq \zeta \leq N/2$, where $N = 120$.

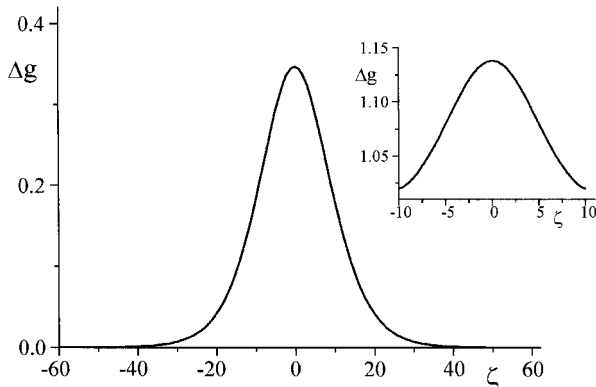

Figure 4. The difference $\Delta g = g(\zeta) - g$ as a function of $\zeta = z/d_0$. The number of smectic layers between the switched areas is $N = 120$. The inset: The difference Δg at $N = 20$.

and the free energy density g the cell would have if there were no switching along the z -direction:

$$g = \int_{-L/(2\lambda_{ch})}^{L/(2\lambda_{ch})} [g_n(\xi) + g_s(\xi)] d\xi.$$

The energy increases significantly around $\zeta = 0$, where the deformation in ϑ and φ is concentrated. The increase

in dimensionless free energy associated with the wall is obtained as

$$\Delta G = \int_{-N/2}^{N/2} [g(\zeta) - g] d\zeta.$$

From the considerations in §2.1.2 we calculate the increase in the free energy:

$$\Delta F = \frac{K}{C_k R} \Delta G.$$

At the chosen set of parameters and $L = 2 \mu\text{m}$ the energy associated with the wall is $7 \times 10^{-12} \text{ J m}^{-1}$. Assuming that the switch from one stable state to the other is obtained by the application of an external electric field, we can also estimate the reduction in free energy when the director switches from one stable state to the other. When a voltage U is applied across the cell the reduction in the electrical free energy is approximately $2PUd_0$ in one smectic layer. At $P = 50 \mu\text{C m}^{-2}$ and $U = 1 \text{ V}$ this amounts to $\sim 3 \times 10^{-13} \text{ J m}^{-1}$ per layer. The energy associated with the wall is thus of the order of the energy reduction inside a few tens of switched layers.

Now we have the information needed to answer several questions regarding the pixel switching:

- (1) The number of smectic layers which need to be switched so that the decrease in the free energy due to switching is greater than the increase in free energy due to wall formation gives an estimate of a minimum pixel width needed for the switch actually to occur.
- (2) If, on the other hand, we have a prescribed width over which the voltage is applied then with the above procedure the voltage needed to switch the director can be found.
- (3) The width of the wall (λ_w) between switched areas is approximately 50 smectic layers at a chosen realistic set of parameters (4). With $d_0 = 3 \text{ nm}$ there is thus a region of about $0.1 \mu\text{m}$ between the two switched areas where the director is in none of the bistable states. This width is negligible compared with the common pixel widths which are of the order of tens of μm .

It becomes rather energy costly if we want to switch layers that are less than $N_w = \lambda_w/d_0$ layers apart. The increase in free energy as a function of the number of smectic layers between the switched areas is shown in figure 5. At $N < N_w$ the wall energy increases significantly. The layers that are closer than N_w layers apart can still be switched, but a higher price is paid to achieve switching. The energy associated with the wall is already $2 \times 10^{-11} \text{ J m}^{-1}$ at $N = 20$, which is a few times larger than at $N = 120$ (see also the inset to figure 4). At

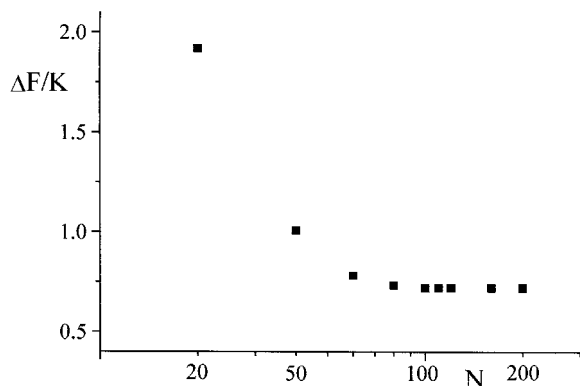

Figure 5. The increase in the free energy (ΔF) due to the wall formation as a function of a number (N) of smectic layers between the switched areas. K is the nematic elastic constant.

$N > N_w$ the wall energy remains constant regardless of the number of intermediate layers. By increasing the number of intermediate layers above N_w we simply increase the width of the pixel. An important conclusion follows from this result (see figure 6): the width of the region Δz_E , along which an external field has to be applied across the cell, has to be large enough that the free energy decrease due to the electrical term covers the energy increase due to the wall formation. This gives the minimum width of the region over which the electrical field must be applied. The pixel width (Δz_p) can be much greater, however; its width is determined by the distance between the two regions in which the electric field is applied minus the wall width.

Finally we study the temperature dependence of the energy associated with the wall formation (ΔF) and the width of the wall (λ_w). The temperature dependent parameter is $|c_\perp|$. The temperature dependence is best presented by the variation of the reduced temperature $t = T/T_{AC} - 1$, which is 0 at the bulk smectic A–smectic C phase transition temperature, and is negative in the

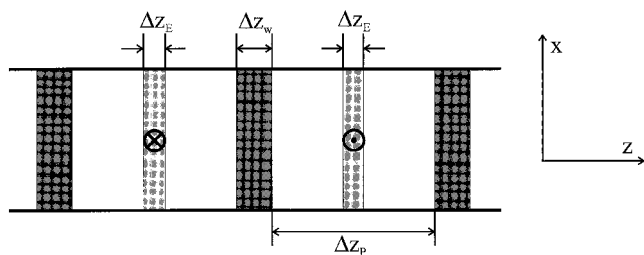

Figure 6. The width of the switched region. The width over which the electric field is applied is Δz_E . The width of the wall formed between two switched areas is Δz_w . In this region the director switches from the \bullet to the \times state. The actual width of the switched area is Δz_p and can be wider than Δz_E .

smectic C phase. The dimensionless parameter C_R is related to the reduced temperature as $C_R = c_\parallel / |c_\perp| = (a_0 |t|)^{-1}$, where a_0 is of the order of 1 [15].

To study temperature dependence we have chosen the following set of parameters: The values at $|t| = 0.1$ are given in (4). The following temperature dependences can easily be found:

$$\tan \vartheta_B \propto |t|^{1/2}, \quad C_R \propto |t|^{-1}, \quad R \propto |t|^{-1/2}.$$

Since the chevron width diverges when the temperature approaches the smectic C–smectic A phase transition temperature, we have to send the cell boundaries to infinity in order to study only the effects inherent to the chevron structure and disregard the surface effects. In calculation we have thus chosen $L = 100 \mu\text{m}$. Results are also shown for $L = 2 \mu\text{m}$, where the effect of the confined system can already be seen. Since no surface orientational effect was considered at $L = 2 \mu\text{m}$, these results would be valid only in the case of a non-physical surface condition with no preferred anchoring orientation at the surface.

The width of the wall as a function of the reduced temperature is shown in figure 7. The width increases as the absolute value of the reduced temperature decreases. At $L = 100 \mu\text{m}$ the dependence obeys a power law: $\lambda_w \propto |t|^{-0.5}$. At $L = 2 \mu\text{m}$ we observe a slight deviation from this power law. We can also estimate this power law from the dimensionless free energy densities, see equations (2) and (3). The leading term that opposes the director rotation on the cone from one stable state, with the y -component of the director equal to $l(\xi, \zeta = -N/2)$, to the other stable state, with $l(\xi, \zeta = N/2) = -l(\xi, \zeta = -N/2)$, is in the nematic free energy density, equation (2), and is $C_R R^2 l_\zeta^2 / 2$. The dimensionless constant in front of the l^2 -term in the smectic elastic free energy density, equation (3), is of

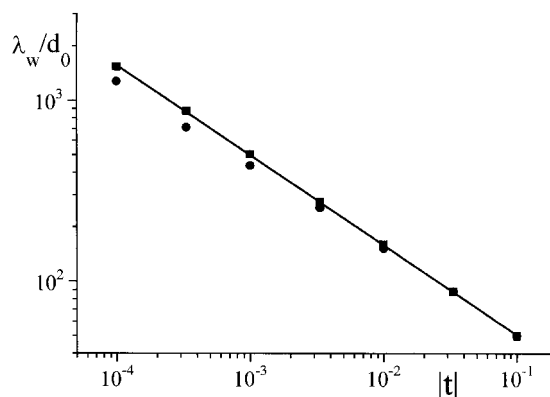

Figure 7. The width of the wall (λ_w) as a function of the reduced temperature $|t|$. Squares: $L = 100 \mu\text{m}$; circles: $L = 2 \mu\text{m}$; full line: the best power law fit to the numerical results obtained with $L = 100 \mu\text{m}$.

the order of 1. We can thus expect that the variation of $l(\zeta)$ will be significant over the region with the width of the order of $\sim d_0 (C_K R^2)^{1/2}$. Since $R \propto \lambda_{ch} \propto |t|^{-1/2}$ the wall width can be expected to follow the same power law dependence as the chevron width: $\lambda_w \propto |t|^{-1/2}$. Numerical calculations confirm this rather rough estimate.

In figure 8 we show the temperature dependence of the wall energy. The energy associated with the wall formation increases as the absolute value of the reduced temperature increases (i.e. as we go deeper into the smectic-C phase). We note that the energy depends on the cell thickness since the deformation of ϑ and φ at the wall ($\zeta \sim 0$) extends across the whole cell, i.e. from $x = -L/2$ to $x = L/2$. At $L = 100 \mu\text{m}$ the wall energy obeys a power law dependence on temperature: $\Delta F \propto |t|^{1.5}$. At $L = 2 \mu\text{m}$ we see deviation from this power law at $|t| < 0.01$ where first the width of the wall due to the switch between two states, and then the chevron width, become comparable to the cell thickness.

The energy power law dependence can again be estimated from the model. Let us assume an extremely simplified situation with a bookshelf geometry of the smectic layers. Let the director inside one layer lie in the yz -plane everywhere in the layer. Also the molecular cone angle is the same everywhere in the layer. The situation is similar to that shown in figure 1. The director switches between two stable states. The director in the layer that lies in the centre of the wall lies in the xz -plane (no director pretilt in the yz -plane which is favoured by the smectic C phase). The free energy density that a bookshelf structure has in either stable state is approximately $-|c_\perp| q_0^2 \eta_B^2 \vartheta_B^2$ (for a more detailed expression see refs. [4] and [5]). At the centre of the wall between the stable states $\vartheta = 0$ and the free energy density of such a structure

would be approximately 0. Because q_0 and η_B are temperature independent, the free energy associated with the wall formation is proportional to $|c_\perp| \vartheta_B^2 \lambda_w \propto |t| |t|^{-1/2} = |t|^{3/2}$. A more detailed numerical calculation confirmed this power law dependence.

4. Conclusions

We have studied theoretically the pixel wall properties in surface-stabilized smectic C cells. Using the Landau–de Gennes model we determined the structure and energy of the wall formed between two states in cells with a uniform chevron direction. The director rotation from one state to the other occurs in the middle between the regions in which two opposite states are stabilized by, for example, the application of an external electric field. The width of the wall is temperature dependent and it obeys the power law $\lambda_w \propto |t|^{-0.5}$, as long as the cell thickness is much larger than the wall width and the chevron tip width. Far from the smectic C–smectic A phase transition temperature the wall width is a few tens of smectic layer widths, and the energy associated with the wall formation is comparable to the energy reduction due to the application of the electric field over a few smectic layers. The wall energy also obeys a power law dependence on temperature: $\Delta F \propto |t|^{1.5}$, as long as the cell thickness is much larger than the wall width and the chevron tip width.

References

- [1] RIEKER, T. P., CLARK, N. A., SMITH, G. S., PARMAR, D. S., SIROTA, E. B. and SAFINYA, C. R., 1987, *Phys. Rev. Lett.*, **59**, 2658.
- [2] OUCHI, Y., LEE, J., TAKEZOE, H., FUKUDA, A., KONDO, K., KITAMURA, T., and MUKOH, A., 1988, *Jpn. J. appl. Phys.*, **27**, L725.
- [3] HANDSCHY, M. A. and CLARK, N. A., 1984, *Ferroelectrics*, **59**, 69.
- [4] VAUPOTIČ, N., KRALJ, S., ČOPIČ, M., and SLUCKIN, T. J., 1996, *Phys. Rev. E*, **54**, 3783.
- [5] VAUPOTIČ, N., ČOPIČ, M., and SLUCKIN, T. J., 1998, *Phys. Rev. E*, **57**, 5651.
- [6] CLARK, N. A., and RIEKER, T. P., 1988, *Phys. Rev. A*, **37**, 1053.
- [7] CLARK, N. A., RIEKER, T. P., and MACLENNAN, J. E., 1988, *Ferroelectrics*, **85**, 79.
- [8] MACLENNAN, J. E., HANDSCHY, M. A., and CLARK, N. A., 1990, *Liq. Cryst.*, **7**, 787.
- [9] MACLENNAN, J. E., CLARK, N. A., HANDSCHY, M. A., and MEADOWS, M. R., 1990, *Liq. Cryst.*, **7**, 753.
- [10] WILLIS, P. C., CLARK, N. A., and SAFINYA, C. R., 1992, *Liq. Cryst.*, **11**, 581.
- [11] DE GENNES, P. G., 1972, *Solid State Commun*, **10**, 753.
- [12] LUBENSKY, T. C., 1995, *Physica A*, **220**, 99.
- [13] LUBENSKY, T. C., and RENN, S. R., 1990, *Phys. Rev. A*, **41**, 4392.
- [14] DE GENNES, P. G., and PROST, J., 1993, *The Physics of Liquid Crystals* (Oxford: Clarendon Press).
- [15] MARTINEZ-MIRANDA, L. J., KORTAN, A. R., and BIRGENEAU, R. J., 1986, *Phys. Rev. Lett.*, **56**, 2264.

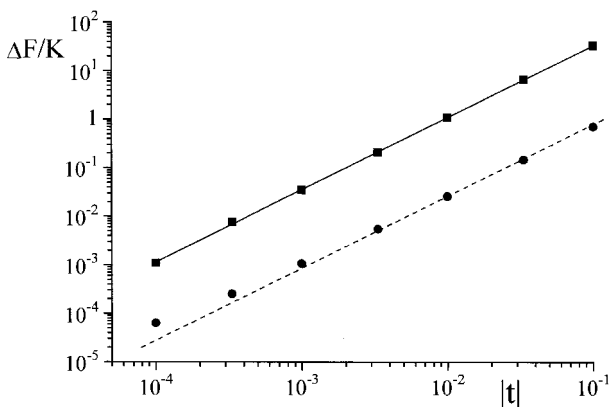

Figure 8. The energy associated with the wall formation (ΔF) as a function of the reduced temperature $|t|$. K is the nematic elastic constant. Squares: $L = 100 \mu\text{m}$; circles: $L = 2 \mu\text{m}$; full and dashed lines: the best power law fit to the numerical results obtained with $L = 100 \mu\text{m}$.